

C 2 0 0 L

IRIDIUM CERTUS® 200 Land Terminal



FEATURES

IRIDIUM CERTUS® TERMINAL DESIGNED FOR FIXED LAND APPLICATIONS

The Intellian C200L has been designed and manufactured as a small and lightweight fixed land terminal, perfect for use where traditional terrestrial connectivity is unavailable or as a back up in the event that the terrestrial network is unavailable. It can be used for a range of applications including business continuity, remote community and disaster response. It is also an ideal solution to provide out of band management for VSAT terminals.

The Intellian C200L provides IP data speeds of up to 176 kbps (up and down) and supports multiple concurrent voice calls. Customers will gain both scalability and advanced performance over the Iridium Certus network whenever needed.

LOWER TOTAL COST OF OWNERSHIP

Intellian focus on delivering value to our customers through low total cost of ownership. This comes from building highly reliable terminals that are easy to install and have a wide range of features and functionality that reduces the amount of additional equipment required. Intellian's responsive global support teams are there to help if needed and the terminal comes with a market leading 3 year parts and labour warranty.

ALL-IN-ONE SOLUTION

The C200L delivers unparalleled features and functionality that include: WAN mediator, Wi-Fi antenna, built-in soft PBX & firewall. Bringing all these features together in one package simplifies installation & configuration, and eliminates the possibility of conflicts that can occur when these features are provided using connected equipment.

TRUE GLOBAL COVERAGE WITH IRIDIUM CERTUS®

The Intellian Certus C200L satellite terminal utilizes the Iridium Certus network of Low-Earth Orbit (LEO) satellites, providing low latency, high speed and always-on communication. Powered by a uniquely sophisticated global constellation of 66 cross-linked Low-Earth Orbit (LEO) satellites, the Iridium® network provides high-quality voice and data connections over the planet's entire surface.

SYSTEM HIGHLIGHTS

- Designed for the land market
- IP data speeds of 176 kbps up and down
- Includes dedicated interference blocking elements, making the terminal inherently resilient to interference from terrestrial cellular equipment
- Easy installation and simple configuration
- Built-in WAN mediator
- Wi-Fi antenna
- Built-in firewall
- Three simultaneous high quality voice lines
- 4-Port Ethernet (LAN) PoE and WAN
- Connect up to 16 SIP phones with Soft PBX function
- Designed for 10-year operational lifetime
- 3-year global warranty - parts and labour

C200L

IRIDIUM SERVICES

Voice 3 simultaneous HD voice lines
 IP Data **Uplink:** up to 176 kbps / **Downlink:** up to 176 kbps

PHYSICAL

ADU Dimensions 240 x 145 mm / 9.45" x 5.71"
 ADU Weight 3.5 kg / 7.7 lb
 BDU Dimensions 280 x 190 x 41 mm / 11" x 7.2" x 1.45"
 BDU Weight 1.2 kg (stand-alone type) / 2.6 lb

POWER

DC Input 10.8 ~ 30 V DC
 Power (max) 110 W

RF / ANTENNA

Tx Frequency 1616 MHz ~ 1626.0 MHz
 Rx Frequency 1616 MHz ~ 1626.5 MHz
 Antenna Gain L2 Class
 Antenna Connectors TNC female (ADU) – TNC female (BDU)
 GNSS GPS, GLONASS, Galileo
 Wi-Fi 802.11 b/g

APPROVAL

Certification CE/RED, FCC, RoHS, ETSI

ENVIRONMENTAL CONDITIONS

Operating Temp. range **ADU:** -30°C ~ + 55°C, **BDU:** -15°C ~ + 55°C
 Operating Humidity range More than 95%
 Water Ingress **ADU:** IP66, **BDU:** IP31
Shock: IEC60068-2-27 (operation), IEC60721-3-6 Class 6M3 (survival)
Vibration: IEC60945 (operation), IEC60721-3-6 Class 6M3 (survival)

I/O

LAN 3 x RJ45 (2 PoE)
 WAN 1 x RJ45
 Analog Phone 1 x RJ14 (2 x Analog Phone)
 Wireless Wi-Fi Antenna (SMA-RP)
 I/O 10 pin GPIO
 Others SIM, Reset, On/Off, Ground

Global HQ

Innovation Center
 Intellian Technologies, Inc
 T +82 31 379 1000

APAC

Seoul
 Intellian Technologies, Inc.
 T +82 2 511 2244

Americas

Irvine
 Intellian Technologies USA, Inc.
 T +1 949 727 4498 Toll Free +1 888-201-9223

EMEA

Rotterdam
 Intellian B.V.
 T +31 1 0820 8655

Mackay
 COMMUNICATIONS
 www.mackaycomm.com
 +1 919 850 3100
 satserv@mackaycomm.com
 Satellite PTT, Voice & Data
 Equipment and Airtime

SYSTEM DIMENSION

ADU

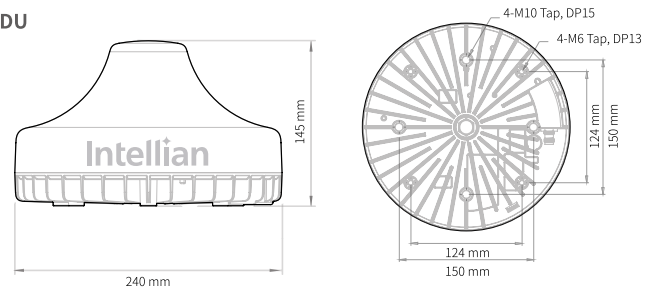

BDU

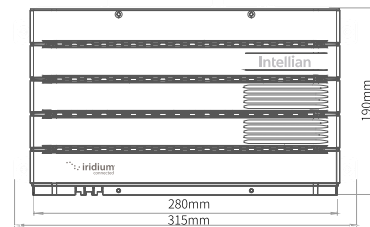

BDU with 19" rack mounting kit fitted

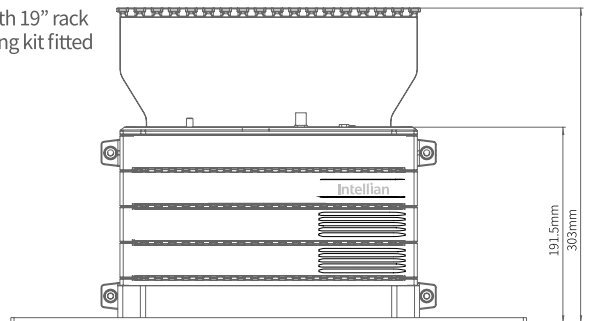

SYSTEM DIAGRAM

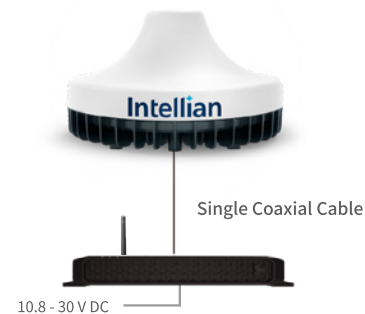

Part No. C200L_DS_v2.2_240201