

FURUNO®

20.1" High-resolution Multi-color LCD

MARINE RADAR

Models FAR-2157/2167DS



picture credit: ALBACORA SA, PESQUERAS ECHEBASTAR S.A.

- ▶ High output power radar delivers long-range detection capability
- ▶ Advanced signal processing for improved detection of small targets, buoys and birds
- ▶ Straightforward operation using customizable Function & Direct Key, trackball/wheel palm module and rotary controls
- ▶ Up to four radar sets can be networked via Ethernet without an extra device
- ▶ Target trail with its various functions enhances situation awareness of vessel traffic around the vessel
- ▶ All Echo Area Mode lets the operator observe a wider picture area around the vessel



The future today with FURUNO's electronics technology.

FURUNO ELECTRIC CO., LTD.

9-52 Ashihara-cho, Nishinomiya City, Japan Phone: +81 (0)798 65-2111
Fax: +81 (0)798 65-4200, 66-4622 URL: www.furuno.co.jp

Catalogue No. R-192

TRADEMARK REGISTERED
MARCA REGISTRADA

FURUNO high-performance radar for fishing ***improved detection***

The FAR-2157 (X-band) and 2167DS (S-band) are the latest additions to the world-renowned FAR-21x7 series radar. Their software and hardware are optimized for fishing operations, and they carry all the standard functions of the FAR-21x7 series.

Both radar incorporate state-of-the-art signal/graphics processing technology together with auto tuning, logarithmic amplifiers and anti-clutter controls, for superb detection on all ranges. Thanks to its graphics processing technology, the echoes are expressively presented with 32 gradations in accordance with reflected echo strength. The anti-clutter controls suppress the unwanted echoes from waves, rain and clouds. The combination of these technologies ensures a clear image, even in rough seas.

The FAR-2157 and 2167DS deliver a variety of useful functions to skippers. Direct Key control allows the operators to activate specific settings with just a few keystrokes. This feature is particularly important to one-man fishing operations, where quick setup of the radar according to sea conditions is vital.

ARPA and echo trail functions are available to monitor the movement of targets precisely. With ARPA, the targets are automatically or manually acquired, and their movements, CPA and TCPA are computed and shown in the cells on the right hand side of the screen. (For acquisition of smaller targets such as birds and buoys, they have to be manually acquired.) In addition, those ship's tracks can be indicated in color, which the operators can select from eight different colors. For extended monitoring of target movement, the echo trail feature is recommended. The trail color can be shown in 12 colors. When the multi color trail is selected, the trail color changes over time. True motion echo trail is also available.

The FAR-2157 and 2167DS consist of an antenna, 20.1" LCD display, processor and control unit. For those who prefer a different monitor, the BlackBox radar configuration is also available. The control unit is selectable from Full-keyboard Control Unit and Palm Control Unit. With a Palm Control Unit, all operations can be done by the trackball.



► Function & Direct Keys

30 often-used functions such as Anti-clutter Control or Echo Stretch, which are customizable, are provided in the pre-set menu. F1 through F3 keys can be set up to access the programs. (Function Keys)

You can also add 10 Direct Keys that memorize up to 10 steps of user-programmable actions on the F4 key.

When you are in a specific situation where rapid action is required, you can switch to the saved settings quickly with one hand operation.

BlackBox configuration types are also available!

The BlackBox radar, consisting of an antenna, processor and control unit. They work with virtually any size multi-sync SXGA (1280x1024) LCD monitor. FURUNO also offers a premier line of high-quality LCD monitors that are a perfect complement to the FAR-2157-BB and 2167DS-BB radar systems.

- **Supports non-interlaced SXGA (1280x1024) monitors with DVI-D input**
- **Presentation of very high-quality radar image by employing new Digital Video Interface (DVI) techniques**



g vessels delivers on of vessels, birds, buoys and net floats.



S-BAND



S-band antenna for FAR-2167DS
60 kW TR up
(10 or 12 ft ANT selectable)

The FAR-2167DS is a high-performance S-band radar with 60 kW of output power.

Detection and tracking of sea birds from a distance has always been very important for commercial fishermen. The noticeable advantage of the FAR-2167DS is its capability to detect flocks of seabirds. S-band radar also assures target detection in adverse weather where an X-band is heavily affected by sea or rain clutter.

X-BAND



X-band antenna for FAR-2157
50 kW TR up
(8 or 10 ft ANT selectable)

The FAR-2157 radar is suitable for detection of vessels and buoys under most sea conditions. The 50 kW high-power output enables long range detection and its long antenna delivers high-resolution images.



100 Base-TX Ethernet Network System

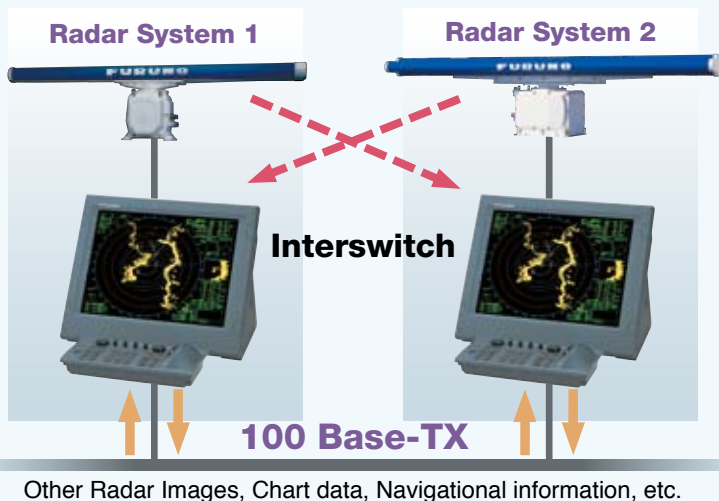

The radar can be connected to an Ethernet network for a variety of user requirements. Up to four radar systems both X- and S-band can be networked without using an extra device.

In addition, the essential navigational information including the electronic chart, L/L, COG, SOG, STW, etc. can be shared within the network.

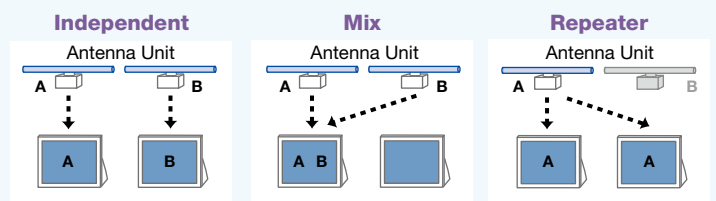

▶ All Echo Area Mode

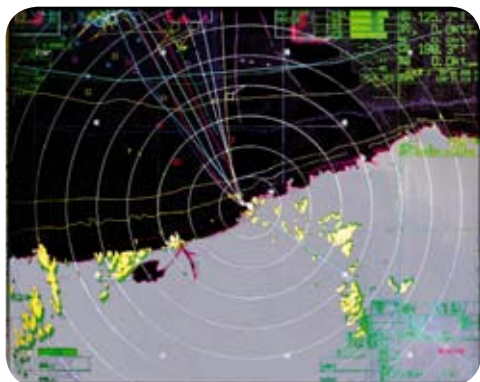

The radar has three modes to display the echo area: CIRCLE, WIDE, and ALL.

With "All" Echo Area Mode, the entire screen is filled with an echo image. Its full-screen echo presentation capability allows the operator to observe a wider overview of the surrounding area, a function vital in fishing operations.

Selectable display mode for echo area

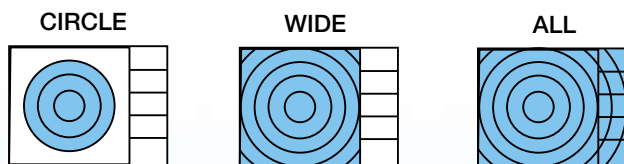

■ : the area where radar echo is displayed

▶ Chart Overlay



Overlay with FURUNO chart

The radar incorporates a Video Plotter that displays electronic charts, plots own and other ship's tracks, enables entry of waypoints/routes and makes a radar map. The chart may be displayed in combination with radar images.

It is compatible with FURUNO or Navionics charts.

▶ Target Trail



The target trails feature generates a monotone or gradual shading afterglow on all objects on the display. The trails are useful in showing own ship movement and other ship tracks. True* or Relative echo trail is available in Relative Motion. (only True echo trail is selectable in True Motion)

Even if the plotting interval or display setting are changed, trails remain on the screen and the trail length will change according to the new setting.

*Heading sensor required

Long Trail Mode

Target trails are memorized for the duration of your selected trail time from 15 seconds to 48 hours.

Narrow Trail Mode

Target trails can be painted with thinner lines if desired. This is useful when there are a lot of targets on the screen that need to be easily distinguished.

Multi-color Trail Mode

The target trails change their colors in 12 gradations. The color changes as time passes. This makes it easier to know the movement and speed of targets.

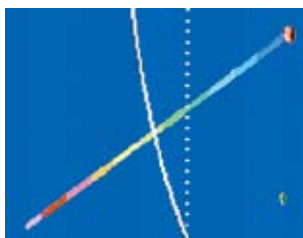

Own Ship Trail OFF

This radar has functions to automatically prohibit the unwanted trail which is generated around your vessel according to the sea clutter level.

Trail Eraser

The generated trails of other vessels or sea clutter can be erased with the trail eraser. It is useful for deleting unwanted trails that are near your vessel.



► Marks and Comments

Marks can be placed on the radar screen to note certain positions of importance. Comments can be placed near the mark to aid in their identification. Marks allow a skipper to grasp the relative position between own vessel and mark locations.

With this function, a skipper can enter the GPS position data* of the fishing grounds and hazardous objects for navigation such as shallow waters.

*GPS sensor required



Up to 8 letters can be typed to each mark



Examples of marks (available in seven colors)

► Guard Zones

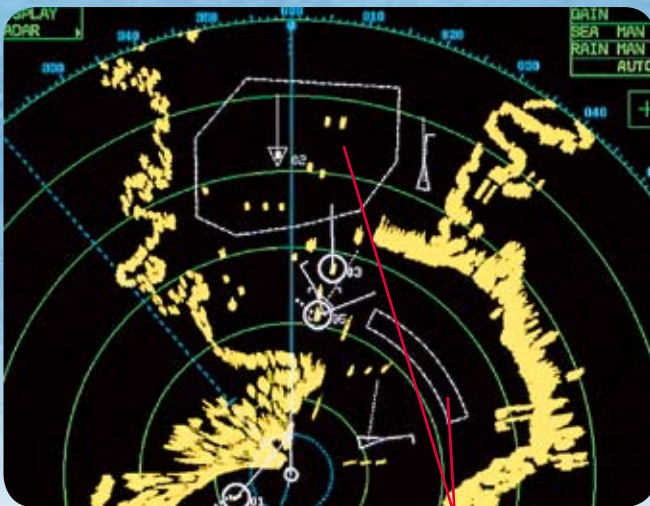

Guard Zones

Automatic Acquisition Zone

Two automatic acquisition zones may be set in a sector in the shape desired. They also act as suppression zones, avoiding unnecessary overloading of the processor and clutter by disabling automatic acquisition and tracking outside of them. Targets in an automatic acquisition zone are shown with an inverse triangle. The operator can manually acquire important targets without any restrictions.

Guard Zones and Anchor Watch Zone

Guard Zones generate visual and audible alarms when targets enter the operator-set zones. One of the Guard Zones may be used as an anchor watch to alert the operator when own ship or targets drift away from the preset zone.

CPA Alarm

The target tracking symbol changes to a triangle when its predicted course (vector) violates the operator set CPA/TCPA. The operator can readily change the vector lengths to evaluate the target movement trend.

► Presentation Colors

The radar screen can be presented in a variety of colors for easy observation under all lighting conditions.



ARPA/AIS

Target automatically acquired

AIS-equipped target selected for data reading



Own ship data cell

DATA Cell 1

AIS information

Water temp, Depth, Wind

DATA Cell 2

Tracking data

Zoom

DATA Cell 3

Tracking data

AIS Information



Data Display

A variety of navigational information which is vital for fishing vessels, including own ship status, radar plotting data, wind, water temperature and information from other shipborne sensors can be displayed in the data cells on the right hand side of the screen. The FAR-2157 and 2167DS radar have a unique zoom function which enlarges a part of the radar image twice or three times in size.

Target Association (Fusion)

An AIS-equipped ship may be shown on the display by both AIS and ARPA symbols. This happens because the AIS position is measured by a GPS navigator in L/L while the ARPA target blip and data are measured by range and bearing from own ship. When the symbols are within an operator-set criteria, the ARPA symbol is merged into the AIS symbol. The criteria is determined by the differences in range, bearing, course, speed, etc.

Symbols for AIS

SOG (Speed over Ground) and COG (Course over Ground) vector *1

Turning direction (ROT indicator)

Past positions

Heading line *2

*1 Vector shows STW (speed thru water) and CSE (course) when water tracking mode is selected at the radar. The length of the vector changes according to target's speed.

*2 If there is no heading data, the line points in direction of COG.

Sleeping AIS Target

Selected Target

Lost Target

Dangerous Target

Symbols for ARPA

Past positions

Initial stage

Vector shows trend of movement.

Steady tracking

CPA alarm

Lost target (Flashing)

Past Position Display
The ARPA displays equally time-spaced dots marking the past positions of any targets being tracked. A new dot is added during preset time intervals until the preset number is reached. AIS also displays past position dots.

Information to be exchanged

Static Data
MMSI (Maritime Mobile Service Identity)
IMO number (Where available)
Call sign and name
Length and beam
Type of ship
Location of position-fixing antenna on the ship

Voyage related data
Ship's draft
Hazardous cargo (type)
Destination and ETA (at master's discretion)

Short safety-related messages
Free messages

Dynamic data
Ship's position with accuracy indication and integrity status
Coordinated universal time (UTC)
Course over ground (COG)
Speed over ground (SOG)
Heading
Navigation status (manual input)
Rate of turn (where available)
Update rates Dependent on speed and course alternation (2 s - 3 min)

Information to be presented

Bearing from own ship to target in R (Relative) or T (True)
Range from own ship to target
Course Over Ground (COG)
Speed Over Ground (SOG)
Closest Point of Approach of target to own ship (CPA)
Time to CPA (TCPA)
Bow Crossing Range of target (BCR)
Bow Crossing Time of target (BCT)

Selecting the shape of ARPA symbols

After tracking a target, you can select and change the ARPA symbol shape by placing the cursor on the symbol and hitting the "TARGET DATA" key. It is useful to change the ARPA symbol to distinguish vessels and identify groups of related targets.



The ARPA symbols are selectable from 10 shapes.

SPECIFICATIONS OF FAR-2157/2167DS

ANTENNA RADIATORS

- 1. Type** Slotted waveguide array
- 2. Beamwidth and sidelobe attenuation**

	X-Band		S-Band	
	XN-4A	XN-5A	SN-30AF	SN-36AF
Radiator Type				
Length	8 ft	10 ft	10 ft	12 ft
Beamwidth (H)	0.95°	0.75°	2.25°	1.8°
Beamwidth (W)	20°	20°	25°	25°
Sidelobe (within ± 10°)	-28 dB	-26 dB	-24 dB	-24 dB
Sidelobe (outside ± 10°)	-32 dB	-30 dB	-30 dB	-30 dB

3. Rotation

	X-Band		S-Band
	18/22 rpm	22 rpm	21/26 rpm
Rotation			
Gear Box	RSB-106	RSB-107	RSB-111 RSB-112

RF TRANSCIVER

1. Frequency

X-band: 9410 MHz ± 30 MHz
S-band: 3050 MHz ± 30 MHz

2. Output power

	FAR-2157	FAR-2167DS
Output Power	50 kW	60 kW
Transceiver	RTR-083	RTR-084

3. Pulselength/PRF

Range scale (nm)	Pulse length (µs)	PRF (Hz)
0.125, 0.25	0.08	1900
0.5	0.08	1900
0.75, 1.5	0.08, 0.2	1100, 1900
3	0.2, 0.6	1100, 600
6	0.2, 0.6, 1.2	1100, 600
12, 24	0.6, 1.2	600
48	1.2	600
96, 120	1.2	500

4. I.F. 60 MHz

5. Bandwidth
Short pulse: 40 MHz
Medium pulse: 10 MHz
Long pulse: 3 MHz

RADAR DISPLAY

1. Display*

20.1" color LCD (SXGA 1280×1024 pixels),
400 (H) × 320 (V) mm,
Effective display diameter: 308 mm
Echo Color: 12 colors (ex. red, yellow, green, blue, purple) in 24 levels

2. Range scales and ring intervals (nm)

Range	.125, .25, .5, .75, 1, 1.5, 2, 3, 4, 6, 8, 12, 16, 24, 32, 48, 96, 120
Ring	.025, .05, .1, .25, .25, .5, .5, 1, 1, 2, 2, 4, 4, 8, 8, 16, 20

3. Minimum range

30 m on 0.75 nm range scale

4. Range discrimination

30 m on 0.75 nm range scale

5. Range ring accuracy

Within ± 1 %

6. Presentation modes

Head-Up, Course-Up, North-Up, North-Up True Motion

7. Parallel index lines

1, 2, 4 or 6 lines (selectable in menu)

8. Radar map

20,000 points to create coastlines, own ship safety contour, marks, comments, isolated underwater dangers, buoys, traffic routing systems, prohibited areas, fairways.

AUTOMATIC PLOTTING

1. Acquisition

100 targets (e.g. manually 50, automatically 50)

2. Tracking

Automatic tracking of all acquired targets in 0.1 to 32 nm

3. Guard zone

Two zones, one of them 0.5 nm depth

4. Vector

True or relative 30 s, 1-15, 20, 30 min for prediction of target motion

5. Past positions

5 or 10 past positions at intervals of 30 s, 1, 2, 3, 6 min.

6. Collision warning

CPA limit: 0.2 - 10 nm, TCPA limit: 0 - 99 min.

7. Trial maneuver

Dynamic or static, with selected delay time.

AIS DISPLAY

1. Symbols

Sleeping, Activated, Dangerous, Selected, Lost targets

2. Number of targets

1,000 targets max.

3. Data indication

Basic and expanded data

POWER SUPPLY (specify when ordering)

1. Processor Unit

100-115/220-230 VAC, 1ø, 50/60 Hz

3.0 A (100-115 VAC)

1.5 A (200-230 VAC)

440 VAC, 1ø, 50/60 Hz with optional transformer RU-1803

2. Monitor Unit*

100-230 VAC, 1ø, 50/60 Hz

440 VAC, 1ø, 50/60 Hz with optional transformer RU-1803

3. Antenna Unit

FAR-2157:

24 VDC

200 VAC, 3ø, 50 Hz; 220 VAC, 3ø, 60 Hz

100-115/220-230 VAC, 1ø, 50/60 Hz with optional transformer RU-3423

110 VAC, 3ø, 60 Hz with optional transformer RU-5693

220 VAC, 3ø, 50 Hz with optional transformer RU-6522

440 VAC, 3ø, 50 Hz with optional transformer RU-5466-1

FAR-2167DS:

200 VAC, 3ø, 50 Hz; 220 VAC, 3ø, 60 Hz

380 VAC, 3ø, 50 Hz; 440 VAC, 3ø, 60 Hz

110 VAC, 3ø, 60 Hz with optional transformer RU-5693

220 VAC, 3ø, 50 Hz with optional transformer RU-6522

440 VAC, 3ø, 50 Hz with optional transformer RU-5466-1

STANDARD

1. Monitor Unit MU-201CR*

2. Processor Unit RPU-013

3. Standard type Control Unit RCU-014

Trackball type Control Unit RCU-015

(Specify when ordering)

4. Antenna Unit with cable, 15/30/40/50 m (Specify when ordering)

5. Power Supply Unit PSU-006

6. Standard Spare Parts and Installation Materials

OPTION

1. Remote Control Unit RCU-016

2. Gyro Converter GC-10-2 (built in Processor Unit)

3. DVI-RGB Converter Kit (Buffer board built in) OP03-180-2

4. BNC Connector Converter DSUB-BNC-1 (for VDR)

5. Chart/Memory Card Interface Unit CU-200

6. Stepdown Transformer Unit RU-1803/5466-1/5693/6522

7. Rectifier Unit RU-3423

8. Antenna Cable RW-9600

9. External Alarm Buzzer OP03-21

10. Hand Grip Assembly FP03-09840

11. Bracket Assembly FP03-09820

12. Switching Hub HUB-100

* BlackBox types do not include monitor unit.

Antenna Unit for FAR-2157

XN-4A 74 kg 163 lb
XN-5A 79 kg 170 lb

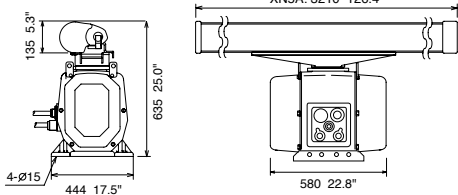

Antenna Unit for FAR-2167DS

SN-30AF 127 kg 280 lb
SN-36AF 133 kg 293.2 lb

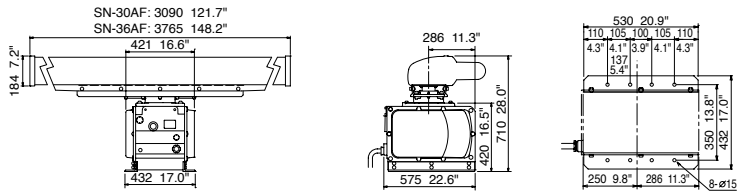

Processor Unit

RPU-013 10 kg 22 lb

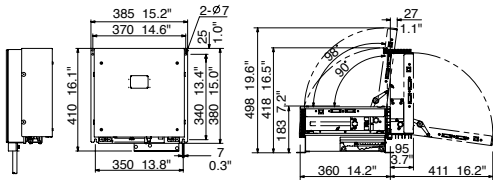

Control Unit Full-keyboard type

RCU-014 3.7 kg 8.2 lb

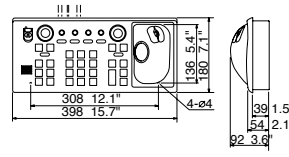

Trackball type

RCU-015 2.4 kg 5.3 lb

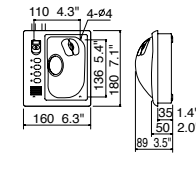

Remote Control Unit

RCU-016 2.4 kg 5.3 lb

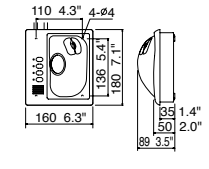

Monitor Unit MU-201CR (BlackBox types do not include the monitor unit)

Bracket mount 17.0 kg 37.5 lb

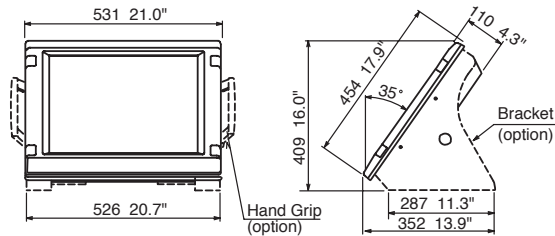

Panel mount 11.0 kg 33.5 lb

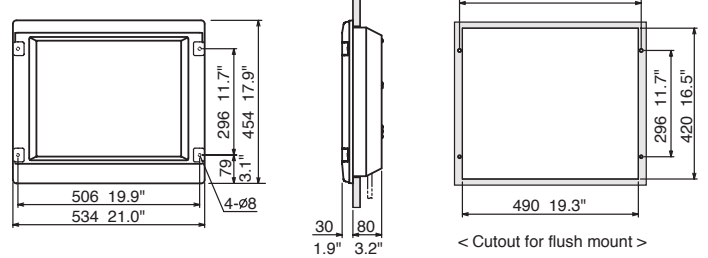

INTERCONNECTION DIAGRAM

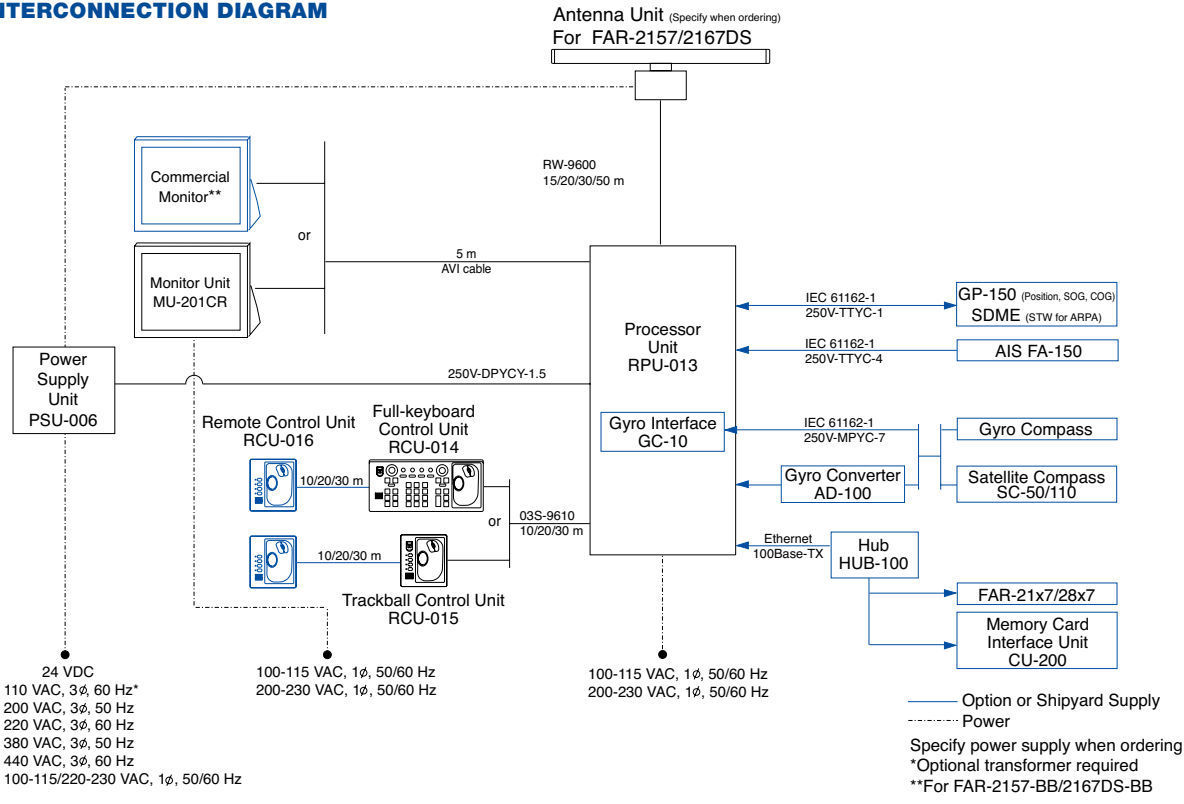

FURUNO U.S.A., INC.

Camas, Washington, U.S.A.
 Phone: +1 360-834-9300
 Fax: +1 360-834-9400

FURUNO (UK) LIMITED

Havant, Hampshire, U.K.
 Phone: +44 2392-441000
 Fax: +44 2392-484316

FURUNO FRANCE S.A.

Bordeaux-Mérignac, France
 Phone: +33 5 56 13 48 00
 Fax: +33 5 56 13 48 01

FURUNO ESPAÑA S.A.

Madrid, Spain
 Phone: +34 91-725-90-88
 Fax: +34 91-725-98-97

FURUNO DANMARK AS

Hvidovre, Denmark
 Phone: +45 36 77 45 00
 Fax: +45 36 77 45 01

FURUNO NORGE A/S

Ålesund, Norway
 Phone: +47 70 102950
 Fax: +47 70 102951

FURUNO SVERIGE AB

Västra Frölunda, Sweden
 Phone: +46 31-7098940
 Fax: +46 31-497093

FURUNO FINLAND OY

Espoo, Finland
 Phone: +358 9 4355 670
 Fax: +358 9 4355 6710

FURUNO POLSKA Sp. z o.o.

Gdynia, Poland
 Phone: +48 58 669 02 20
 Fax: +48 58 669 02 21

FURUNO DEUTSCHLAND GmbH

Rellingen, Germany
 Phone: +49 4101 838 0
 Fax: +49 4101 838 111

LLC "FURUNO EURUS"

St. Petersburg, Russian Federation
 Phone: +7 812 767 15 92
 Fax: +7 812 766 55 52

0612?S Printed in Japan

